

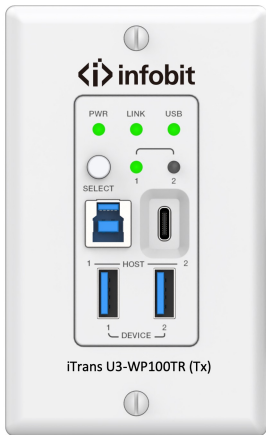

iTrans U3-WP100TR

USB 3.2 Gen 1 Wallplate Extender 100m (US 1-Gang)

User Manual V1.0



www.infobitav.com info@infobitav.com

Thank you for purchasing this product

For optimum performance and safety, please read these instructions carefully before connecting, operating or adjusting this product. Please keep this manual for future reference.

Surge protection device recommended

This product contains sensitive electrical components that may be damaged by electrical spikes, surges, electric shock, lightning strikes, etc. Use of surge protection systems is highly recommended in order to protect and extend the life of your equipment.

Caution

The use of CAT6A F/FTP 23AWG cable is recommended. Please connect in direct interconnection method and do not cross connect.

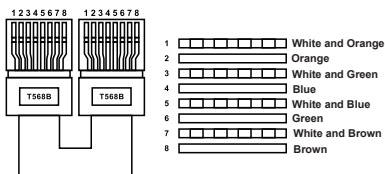

Direct Interconnection Method

Table of Contents

1. Introduction.....	1
2. Features.....	1
3. Package Contents.....	2
4. Specifications.....	2
5. Operation Controls and Functions.....	3
5.1 Transmitter Panel.....	3
5.2 Receiver Panel.....	5
6. API Commands.....	6
7. Application Example.....	9

1. Introduction

This set of US 1-Gang standard decora wall plates can extend USB 3.2 Gen 1 5Gbps signal to a distance up to 100m/328ft via a single CAT6a cable. The transmitter features one USB-C and one USB-B selectable input ports, two USB-A loop out ports. The receiver features one USB-C and three USB-A device ports. Bi-directional 24V PoC (Power over Cable) function allows users to only supply power to either the transmitter or the receiver.

The product can be widely used for long distance USB signal transmission between USB sources and devices like webcams, PTZ cameras, keyboards, mouse devices, USB microphones, flash sticks, printers, scanners, touch panel displays and other USB devices.

2. Features

- ☆ US 1-Gang standard decora wall plate
- ☆ Extension of USB 3.2 Gen 1 up to 100m/328ft over CAT6a cable
- ☆ USB 3.2 Gen 1 connectivity with data transfer rate up to 5Gbps
- ☆ Backwards compatible with USB 2.0 and 1.1
- ☆ Hardware acceleration for isochronous and bulk transfer
- ☆ TX features 1x USB-B and 1x USB-C selectable input ports
- ☆ Support auto switching and manual switching modes
- ☆ Support RS-232 pass-through and API control
- ☆ Support firmware upgrade via USB-C service port
- ☆ Support FSYNC GPIO pass-through for industry camera use
- ☆ RX features 1x USB-C and 3x USB-A output ports (2x 5V@1A and 2x 5V@1.5A)
- ☆ Plug-and-play with no drivers or software download required
- ☆ Support bi-directional 24V PoC (Power over Cable). When TX or RX gets power, the other side does not need an external power supply

3. Package Contents

- ① 1× USB 3.2 Gen 1 Wall-Plate Extender (Transmitter)
- ② 1× USB 3.2 Gen 1 Wall-Plate Extender (Receiver)
- ③ 1× 24V/3.75A Power Supply
- ④ 1× 2pin-3.5mm Phoenix Connector (Male)
- ⑤ 2× 4pin-3.5mm Phoenix Connector (Male)
- ⑥ 2× Mounting Ear
- ⑦ 4× Machine Screw (KM3*4)
- ⑧ 2× Machine Screw (6#-32*34)
- ⑨ 1× Top Panel
- ⑩ 1× User Manual

4. Specifications

Technical	
USB Protocol	USB 3.2 Gen 1
Transmission Rate	Up to 5Gbps
Transmission Distance	100m/328ft via CAT6a (F/FTP) cable 1.5m/4.9ft via USB cable
ESD Protection	IEC 61000-4-2: ±8kV (Air-gap discharge), ±4kV (Contact discharge)
Connections	
Transmitter	Input: 1× HOST 1 [USB Type C, 24-pin female] 1× HOST 2 [USB Type B, 9-pin female] Output: 2× USB-A DEVICE [USB Type A, 9-pin female] 1× HDBT-USB3 [RJ45 connector, 24V PoC] Control: 1× RS-232 [3pin-3.5mm phoenix connector] 1× FSYNC [1pin-3.5mm phoenix connector] 1× SERVICE [USB Type C, firmware update port]
Receiver	Input: 1× HDBT-USB3 [RJ45 connector, 24V PoC] Output: 3× USB-A DEVICE [USB Type A, 9-pin female] 1× USB-C DEVICE [USB Type C, 24-pin female] Control: 1× RS-232 [3pin-3.5mm phoenix connector] 1× FSYNC [1pin-3.5mm phoenix connector] 1× SERVICE [USB Type C, firmware update port]

Mechanical	
Housing	Plastic Front Panel + Metal Enclosure
Color	White
Dimensions	Transmitter / Receiver: 45mm [W] × 42mm [D] × 103.5mm [H]
Weight	Transmitter: 115g; Receiver: 115g
Power Supply	Input: AC 100~240V 50/60Hz Output: DC 24V/3.75A
Power Consumption	62W (Max)
Operating Temperature	0°C ~ 40°C / 32°F ~ 104°F
Storage Temperature	-20°C ~ 60°C / -4°F ~ 140°F
Operating Humidity	20%~80% relative humidity, non-condensing
Storage Humidity	10%~90% relative humidity, non-condensing

5. Operation Controls and Functions

5.1 Transmitter Panel

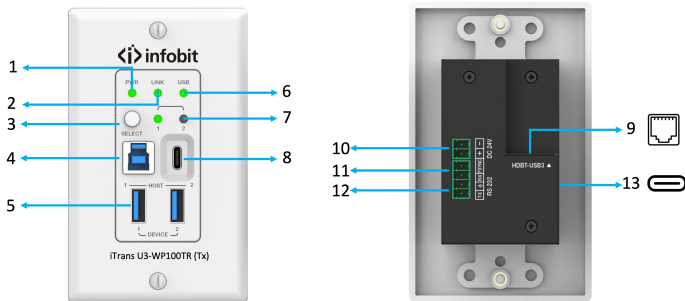

No.	Name	Function Description
1	PWR LED	The green LED will be on when the unit is powered on.
2	LINK LED	The green LED will be on when the Transmitter and Receiver are connected successfully.
3	SELECT button	Press the button to select USB HOST 1/2 circularly.
4	HOST 1	USB-B host port, connected to a PC or host.
5	DEVICE 1, 2	USB-A device ports, connected to USB devices such as U disk or hard disk. Output power is up to 5V/1A.
6	USB LED	USB signal pass-through indicator. <ul style="list-style-type: none"> ▪ On: USB 3.0 signal is detected. ▪ Blinking: USB 2.0 signal is detected. ▪ Off: USB signal is not detected.
7	HOST LED 1, 2	When HOST 1/2 is selected as the input channel, the corresponding LED will be on.
8	HOST 2	USB-C host port, connected to a PC or host.
9	HDBT-USB3	Connects to the HDBT-USB3 port on Receiver with CAT6a cable.
10	DC 24V	DC 24V/3.75A power input port.
11	FSYNC	FSYNC port, the level pass through from Transmitter to Receiver, to synchronize the external devices. Default level range is 0~5V.
12	RS-232	3-pin phoenix connector, connected to a PC or control system for RS-232 command pass-through.
13	SERVICE	USB-C port, used for firmware update.

5.2 Receiver Panel

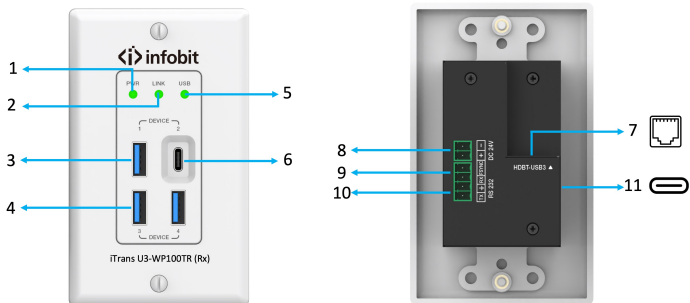

No.	Name	Function Description
1	PWR LED	The green LED will be on when the unit is powered on.
2	LINK LED	The green LED will be on when the Transmitter and Receiver are connected successfully.
3	DEVICE 1	USB-A device port, connected to USB devices such as U disk or hard disk. Output power is up to 5V/1A.
4	DEVICE 3, 4	USB-A device ports, connected to USB devices such as U disk or hard disk. Output power is up to 5V/1.5A.
5	USB LED	USB signal pass-through indicator. <ul style="list-style-type: none"> ▪ On: USB 3.0 signal is detected. ▪ Blinking: USB 2.0 signal is detected. ▪ Off: USB signal is not detected.
6	DEVICE 2	USB-C device port, connected to USB devices such as U disk or hard disk. Output power is up to 5V/1A.
7	HDBT-USB3	Connects to the HDBT-USB3 port on Transmitter with CAT6a cable.
8	DC 24V	DC 24V/3.75A power input port.
9	FSYNC	FSYNC port, the level pass through from Transmitter to Receiver, to synchronize the external devices. Default level range is 0~5V.
10	RS-232	3-pin phoenix connector, connected to a PC or control system for RS-232 command pass-through.
11	SERVICE	USB-C port, used for firmware update.

6. API Commands

The product supports API commands control. Connect the SERVICE or RS-232 port of the product to a PC, then open a Serial Command tool on PC to send API commands to control the product. The API commands list is shown below.

ASCII Commands				
1. Service port (USB-C virtual RS-232) communication protocol (Internal debug) Baud rate: 115200 (fixed), Data bit: 8, Stop bit: 1, Parity bit: none The end mark of command is "<CR><LF>"				
2. Phoenix RS-232 port communication protocol (Connect to control system) Baud rate: 4800~115200 (configurable), Data bit: 8, Stop bit: 1, Parity bit: none The end mark of command is "<CR><LF>"				
Command	Function	Example	Feedback	Default
?	Get the list of all commands	?		
help	Get the list of all commands	help		
get fw version	Get firmware version	get fw version	1.0.0	
set reboot	Reboot the device	set reboot	Reboot... System Initializing... Initialization Finished! FW: 1.0.0	
set reset	Reset to factory defaults	set reset	Sure to RESET to default settings? Type "Yes" after next prompt to confirm...	
get status	Get system status	get status	Please refer to the note at the end of the list.	
set key on/off	Set front panel key on/off	set key on set key off	Set key on Set key off	on
get key	Get front panel key on/off status	get key	Key on	
set baud x	Set RS-232 baud rate to x bps x=1: 4800 x=2: 9600 x=3: 19200 x=4: 38400 x=5: 57600 x=6: 115200	set baud 6	Set baud rate 115200	115200
get baud	Get RS-232 baud rate	get baud	Baud rate 115200	

Command	Function	Example	Feedback	Default
set input x	Set USB host input port (x=1~2) x=1: USB host 1 (USBB) x=2: USB host 2 (USBC)	set input 1	Set input USB host 1	1
get input	Get USB host input port	get input	Input USB host 1	
get usb5v x	Get USB host input port 5V (x=0~2) x=0: all USB host inputs x=1: USB host 1 (USBB) x=2: USB host 2 (USBC)	get usb5v 0	USB host 1: 5V USB host 2: none	
set autoswitch x	Set auto-switching on/off (USB 5V detection) x=On, Off	set autoswitch on	Set autoswitch on	on
get autoswitch	Get auto-switching status	get autoswitch	Autoswitch on	
set tx usbd x power y	Set TX USB device ports (x=0~2) power to (y=0~2) x=0: TX all USB device ports x=1: TX USB device 1 (USBA) x=2: TX USB device 2 (USBA) y=0: Force power off y=1: Follow USB host power y=2: Force power on	set tx usbd 0 power 1	Set TX all USB device ports power follow USB host power	1
get tx usbd x power	Get TX USB device ports (x=0~2) power status x=0: TX all USB device ports x=1: TX USB device 1 (USBA) x=2: TX USB device 2 (USBA)	get tx usbd 0 power	TX all USB device ports power follow USB host power	
set rx usbd x power y	Set RX USB device ports (x=0~4) power to (y=0~2) x=0: RX all USB device ports x=1: RX USB device 1 (USBA) x=2: RX USB device 2 (USBC) x=3: RX USB device 3 (USBA) x=4: RX USB device 4 (USBA) y=0: Force power off y=1: Follow USB host power y=2: Force power on	set rx usbd 0 power 1	Set RX all USB device ports power follow USB host power	1
set hdbt update	Set service port to HDBT UART for FW update	set hdbt update	HDBT update	

Command	Function	Example	Feedback	Default
get rx usbd x power	Get RX USB device ports (x=0~4) power status x=0: RX all USB device ports x=1: RX USB device 1 (USBA) x=2: RX USB device 2 (USBC) x=3: RX USB device 3 (USBA) x=4: RX USB device 4 (USBA)	get rx usbd 0 power	RX all USB device ports power follow USB host power	

Note: The feedback of the command of “get status” is as follow. (The middle line ends with <LF><CR> and the last line ends with <CR><LF>.)

```

=====
Status Info 2-Port USB 3.2 Gen 1 Extender
TX_FW 1.0.0 RX_FW 1.0.0

Source   Key       Baud      Autoswitch
01       On        115200    On

Input    USB_Power
01       5V
02       None

Output   USB_Power
TX_01    Follow_Input
TX_02    Follow_Input
RX_01    Follow_Input
RX_02    Follow_Input
RX_03    Force_Off
RX_04    Force_On
=====

```

7. Application Example

